

- Horizontal blades fixed on 30° deflection with 2/3" spacing.
- Opposed blade damper with slide operator.
- Roll-formed aluminum blades provide stylish appearance.
- Pressure-fit nylon pivot pins provide rattle free performance.
- High quality aluminum extruded frame.
- Countersunk #6 screw hole mounting c/w painted screws.
- Mullions used for sizes over 22" in length.
- Available on 2" increments as standard. Custom sizes available down to 1/16" increments.
- Available with durable powder coat finish.

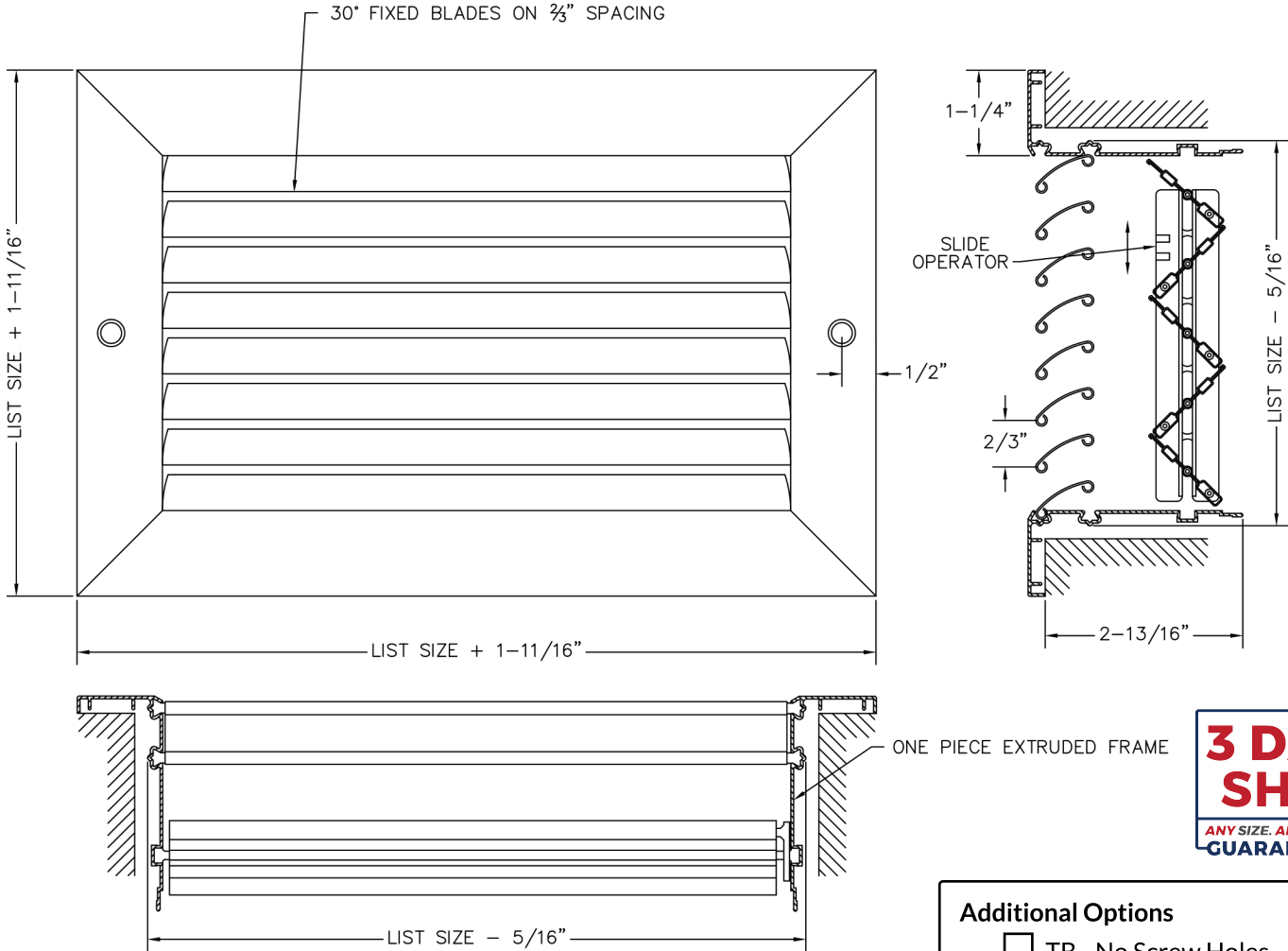

Additional Options

- TB - No Screw Holes
- IS - Insect Screen
- AA - All Aluminum

1. Specify the Length x Height Dimensions

Inches MM _____ x _____

2. Select a Finish

- W White
- S Silver
- M Mill

3. Select a Lead Time

- 3 Day Ship
- Next Friday
- Standard Delivery

Project / Location: _____

Architect: _____

Engineer: _____

Contractor: _____

