

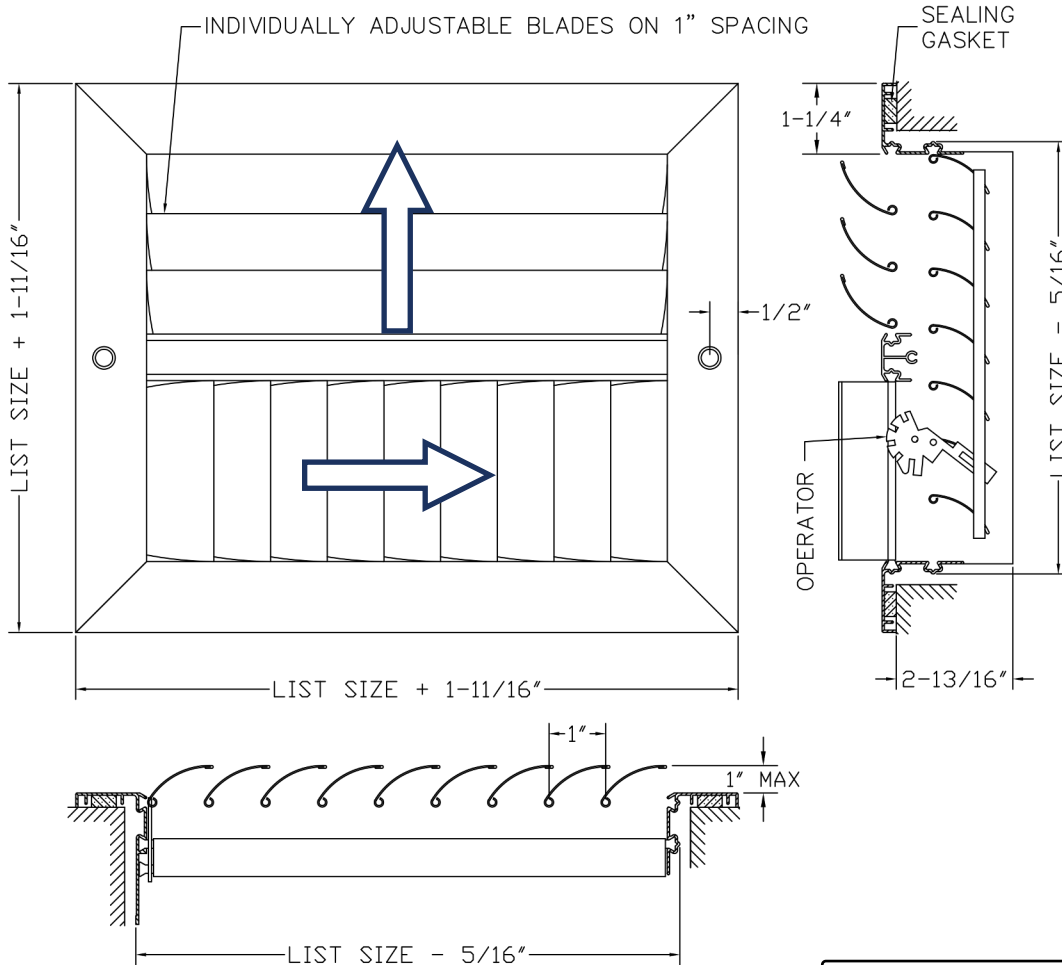

- Horizontal and vertical, adjustable curved blades on 1" spacing.
- Multi-shutter damper with handle operator.
- Pressure-fit nylon pivot pins provide rattle free performance.
- High quality aluminum extruded frame and roll-formed aluminum blades.
- Countersunk #6 screw hole mounting c/w painted screws.
- Mullions used for sizes over 22" in length.
- Available on 2" increments as standard. Custom sizes available down to 1/16" increments.
- Available with durable powder coat finish.



1. Specify the Length x Height Dimensions

Inches MM _____ x _____

2. Select a Finish

- W White
- S Silver
- M Mill

3. Select a Lead Time

- 3 Day Ship
- Next Friday
- Standard Delivery

Additional Options

- TB - No Screw Holes
- AA - All Aluminum

Project / Location: _____

Architect: _____

Engineer: _____

Contractor: _____

